

Installation and Operating Instructions



Art.No. 3104811211

Function

The electronic backwash controller EUROTRONIK-20 switches the filtration pump of a swimming-pool on and off at programmable times and controls the backwashing and clear rinsing cycles for cleaning the filter. The EUROTRONIK, which is mounted on the 6-way valve with a protected quick coupling, automatically moves the valve into the correct position and operates the filter pump. The time of the backwashing and clear rinsing cycles is adjustable and can be seen in the LCD display.

The backwashing cycle can be carried out both on a **time-control** (by way of the integrated digital switch clock) as well as **pressure-dependent** basis. The adjustable pressure switch (art. no. 2000599015) is not included in the delivery package. It is also possible to start the backwashing cycle manually with a key in the housing cover.

A connection for a 230 V motor-operated valve enables withdrawal of the water needed for the backwashing cycle directly from the swimming pool instead of from the overflow collecting tank and replenishment of fresh water during backwashing. **An additional floating relay contact can be used during backwashing to operate a second pump (backwash pump or blower).**

A connection for an external temperature regulator provides the possibility of heating the pool during the filtration times. An internal latch makes sure that the heater will only be enabled when the pump is running.

To empty the swimming pool, the 6-way valve can be moved into the position *Empty*. The key for this is also located in the housing cover. **For maintenance purposes the valve can also be moved into the position *Closed* with a further key.**

The respective valve position and position changes can be read on an LCD display in the housing cover without having to open the housing. The valve disk is lifted before turning to protect the star seal. The pump is switched off during this time.

Technical specifications

Dimensions:	245mm x 140mm x 95mm
Power supply:	230V/50Hz
Power consumption of the controller:	approx.10VA
Breaking capacity:	max. 1,1 kW (AC3)
Motor-operated valve:	230V
System of protection:	IP 54
Ambient conditions:	0-40°C, max. 95% r.H. non condensing
Usable valves:	Praher 1½" and 2"
	Speck 1½" and 2"
	Midas 1½" and 2"
	Astral 1½"
With appropriate adapter	Astral 2"
	Hayward 1½"
Static water pressure:	max.0,3bar
Water column above the valve:	max. 3,0m

The specified valve variants are guide values. Since the design and geometry of the valves can change and these sometimes show significant sample variations, compatibility with the EUROTRONIK may need to be requested from the valve manufacturer.

Table of contents

	Seiten
Function	1
Technical specifications	1
Mounting	3
Preparation of the 6-way valve	3
Preparation of the controller	3
Mounting on an Astral 2" valve	4
Mounting on Astral, Midas and Hayward valves	4
Mounting of the EUROTRONIK	4
Electrical connection	5
Operating elements	6
LCD display	6
Switching the controller on/off	7
Manual control of the filter pump	7
Setting the time	7
Programming the timer (backwashing and clear rinsing times)	8
Programming the timer (filtration times)	8
Backwashing (manual)	9
Emptying the swimming pool	9
Closing the valve	9
DIP switch on the <u>upper</u> circuit board	10
Intermittent backwashing	10
Fortnightly backwashing	10
Service terminal (only for service personnel)	11
Operating cycles of the backwash controller	11
Input signals	11
Microswitch	11
Light scanners	11
Heater	11
Filter pump	12
Auxiliary pump	12
Motor-operated valve	12
Servomotor	13

Mounting

The controller must be mounted in accordance with its system of protection so that it is protected against moisture. The ambient temperature should lie between 0° C and + 40° C and should be as constant as possible. The relative humidity should not exceed 95% and no condensation should occur. Direct incidence of heat or sunlight on the device must be avoided.

The power supply to the device must be connected via an all-polar main switch with a contact gap width of at least 3mm. **The device must be switched off before the housing is opened.**

Preparation of the 6-way valve

Before mounting the EUROTRONIK it must be ensured that the valve moves easily and is free of dirt.

The 6-way valve must be in the position *Filter* when mounting the controller. In this position the handle of the valve must be removed by driving the fastening pin out of the valve shaft. Then insert the shorter osf pin delivered with the device in the middle of the hole in the valve shaft. If the pin is too loose in the hole, it can be fastened with a little adhesive or grease to facilitate mounting of the controller. For later operation of the system it is immaterial whether the pin is loose because it is centred by the housing of the controller.

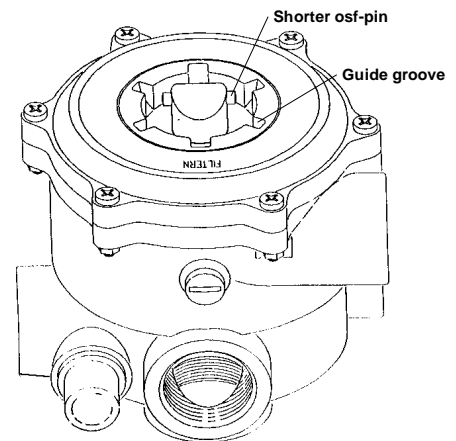

Preparation of the controller

The controller must be in the position *Filter* (position on delivery).

To equalise height differences of the valve shafts, it is necessary in the case of some valves to stick one or more of the self-adhesive spacer disks delivered with the device under the housing of the controller.

Proceed as follows to determine whether one or more spacer disks are needed:

Move the 6-way valve into the position *Filter*.

Mount the EUROTRONIK-10 on the valve without spacer disk. See "Mounting of the EUROTRONIK".

Push the feeler gauge delivered with the device between the EUROTRONIK and valve.

If the feeler gauge fits between the EUROTRONIK and valve exactly, the gap is optimal.

If the EUROTRONIK wobbles on the valve, one or more spacer disks must be stuck under the EUROTRONIK (see sketch below).

Thereafter the EUROTRONIK must be mounted again and the test with the feeler gauge repeated.

After mounting the feeler gauge has to be removed. The resultant play has no negative influence on the operation of the system.

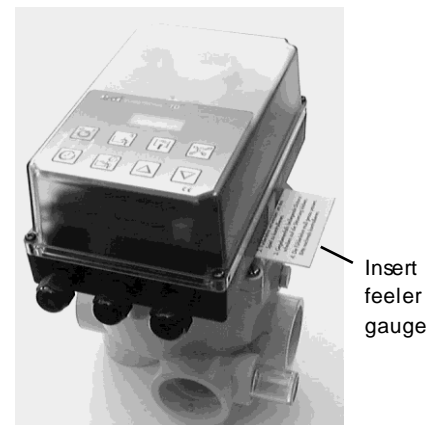

Mounting on an Astral 2" valve

A **special adapter** is needed for mounting on an Astral 2" valve. This adapter is placed on the valve in such a way that:

- the screws point downwards and catch in the recesses in the valve.
- the two recesses on the side point to the words "Filter" and "Backwash".

These adapters are obtainable from **osi** under the article number 1200299200.



Mounting on Astral, Midas and Hayward valves

Since the guide grooves in the valve bonnets of Midas, Astral and Hayward valves are narrower, the two yellow slides on the bottom of the controller must be replaced by the red slides delivered with the device when using these types of valve.

It's not allowable to use an Astral-Valve with bayonet lock!

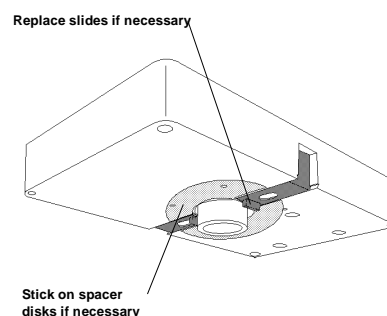

Mounting of the EUROTRONIK

Press the two slides (yellow or red) in completely at the same time.

Place the controller on the valve carefully so that the coupling of the controller encompasses the valve shaft and the pin slides into the slot of the coupling.

Make sure that the coupling is not pushed into the housing of the controller when doing so. Since the coupling does not always fit on the valve shaft easily because of dimensional tolerances in the case of some valves, the housing cover should be closed during mounting.

Then turn the actuator completely **to the right** (approx. 45°).

The slides must then catch in the guide grooves of the valve when released. **The valve shaft may not be turned with the device when clipping on the controller.**

The osf pin in the valve shaft must now be caught in the slot of the coupling.

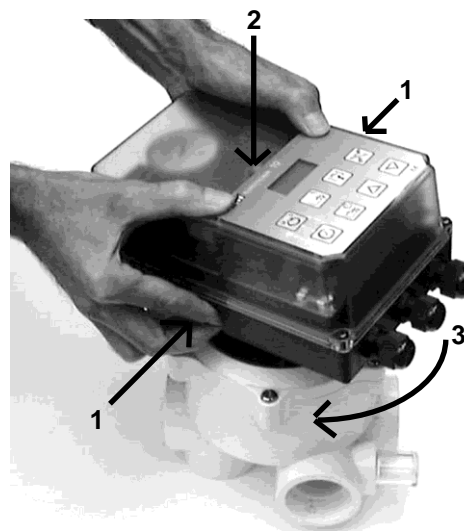

Electrical connection

Only authorised electricians may carry out electrical connection, balancing and service work! The following connection diagrams and all valid safety regulations must be followed. When working on the open housing precautions must be taken to protect the electronic components against electrostatic discharges.

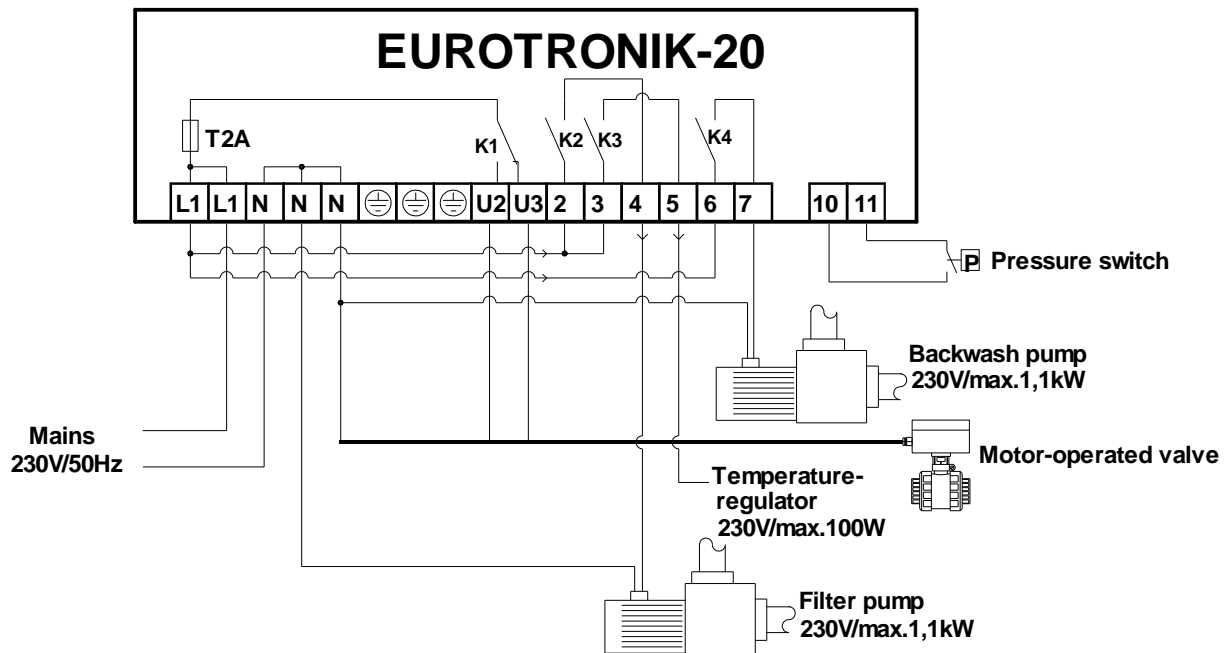

All conductive components must be integrated in the local equipotential bonding system.

The terminals L1 and 2, L1 and 3 as well as L1 and 6 have to be connected.

The contact K2 in the EUROTRONIK is closed when the valve has reached one of its final positions. This prevents the filter pump from being switched on by the filter controller during the adjusting process. In the position Filter this contact is only closed during filtration-time.

The contact K3 in the EUROTRONIK is only closed when the valve is in the final position Filter and the filter pump is running. An external temperature regulator can be connected to terminal 5 which is only supplied with power during filtration time.

The contact K1 in the EUROTRONIK supplies the terminal U2 with power during backwashing, clear rinsing and emptying, while for the rest of the time the terminal U3 is live. A motor-operated valve (230 V) can be connected to these terminals to replenish the water lost during the rinsing cycles.

The contact K4 in the EUROTRONIK is only closed when the valve is in the final position Backwash and can be used to operate an additional backwash pump.

The osf pressure switch (art. no. 2000599015) can be connected to the terminals 10 and 11. It is screwed into the manometer connection in the 6-way valve. The metal body of the pressure switch must be grounded. This switch triggers a backwashing cycle when the pressure limit that has been set is exceeded irrespective of how the switch clock in the EUROTRONIK has been programmed.

Operating elements

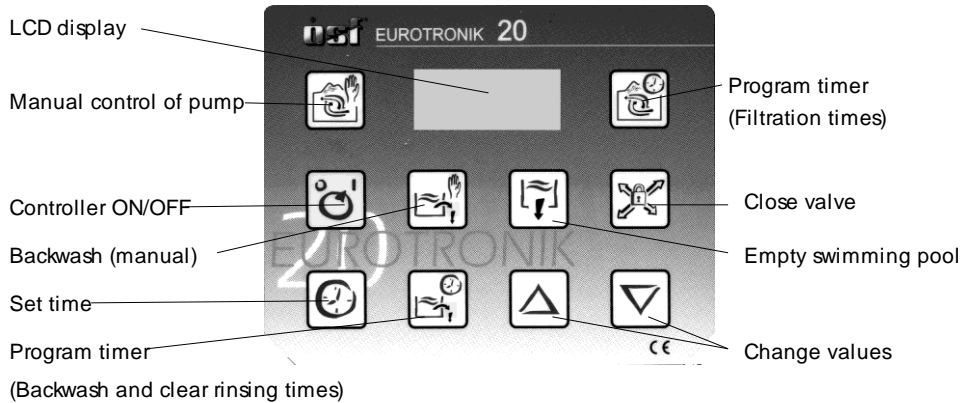

LCD display

Thu 8:46 Filter	Normal operating display during filter time showing the current time and valve position.
Thu 9:18 Pause	Normal operating display without filtration showing the current time.
Thu 6:32 Manually	Normal operating display with manually activated filter pump showing the current time.
Lift → Backwash	The backwashing cycle has been started. The valve disk is first lifted.
Rotate → Backwash	The valve disk is turned into the position <i>Backwash</i> .
Lower → Backwash	The valve disk is lowered into the position <i>Backwash</i> .
4:39 Backwash	The backwashing cycle is running. The remaining backwash time is displayed (in min.:sec.).
Lift → Cl.Rinse	After backwashing the valve disk is lifted again.
Rotate → Cl.Rinse	The valve disk is turned into the position <i>Clear Rinse</i> .
Lower → Cl.Rinse	The valve disk is lowered into the position <i>Clear Rinse</i> .
0:10 Cl.Rinse	The clear rinsing cycle is running. The remaining rinsing time is displayed (in min.:sec.).
Lift → Filter	The valve disk is lifted to be turned into the position <i>Filter</i> .
Rotate → Filter	The valve disk is turned back into the position <i>Filter</i> .
Lower → Filter	The valve disk is lowered into the position <i>Filter</i> .
Lift → Empty	The valve disk is lifted to be turned into the position <i>Empty</i> .

Rotate Empty →	The valve disk is turned into the position <i>Empty</i> .
Lower Empty →	The valve disk is lowered into the position <i>Empty</i> .
Pump on Empty	The valve is in the position <i>Empty</i> . The filter pump is on.
Lift Closed →	The valve disk is lifted to be turned into the position <i>Closed</i> .
Rotate Closed →	The valve disk is turned into the position <i>Closed</i> .
Lower Closed →	The valve disk is lowered into the position <i>Closed</i> .
Valve Closed	The valve is in the position <i>Closed</i> . The filter pump is disabled.
Lift Off →	The EUROTRONIK has been switched off. The valve disk is lifted to be turned into the position <i>Filter</i> (home position).
Rotate Off →	The valve disk is turned into the position <i>Filter</i> (home position).
Lower Off →	The valve disk is lowered into the position <i>Filter</i> (home position).
Machine is off	The EUROTRONIK is off. The valve is in the position <i>Filter</i> .
Switch defect	The bottom final position of the valve disk has not been detected. The microswitch in the bottom part of the housing is possibly damaged. When the fault has been repaired, the controller can be switched off and back on again with the key  .

Switching the controller on/off



The controller is switched on and off with the key . **Note!** This does not switch off the power supply to the device! If the valve is not in the position *Filter* when the controller is switched off, it is turned there automatically.

Manual control of the filter pump







The can be switched on manually with the key .

Setting the time



The time and weekday are set with the key .











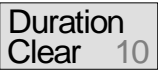

1. Press the key  ⇒ Mon 8:46
time appears in the display.
2. The time can then be set with the keys  and .

To save the time, press the key  again. If, during setting, more than 10 seconds pass without a key being pressed, the last time displayed is saved automatically and the normal operating display appears again.





Programming the timer (backwashing and clear rinsing times)

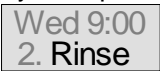

The integrated weekly timer for automatic backwashing and clear rinsing is programmed with the key :

1. Press the key  ⇒  appears in the display.
2. The desired duration of backwashing (in seconds) can then be set with the keys  and . The maximum backwashing time that can be set is 900 seconds (15 minutes). If a backwashing time of 0 seconds is set, the timer is inoperative.
3. Press the key  again ⇒  appears in the display.
4. The desired duration of clear rinsing (in seconds) can then be set with the keys  and . The maximum clear rinsing time that can be set is 120 seconds (2 minutes).
5. Press the key  again ⇒  appears in the display.
6. The desired point in time for backwashing can then be set with the keys  and .
7. Further backwashing cycles can then be programmed as described in points 5 and 6. A total of 15 backwashing cycles per week can be programmed.
8. To save the switch times, press the key  again. If, during setting, more than 10 seconds pass without a key being pressed, the last switch time displayed is saved automatically and the normal operating display appears again.











If backwashing times have already been programmed, they can be deleted with the key :

1. Press the key  repeatedly until the backwashing time that is to be deleted appears in the display .
2. Set the backwash time on  with the keys  and  (between Sun. 23:59 and Mon. 0:00).
3. To delete the switch time, press the key  again.

Programming the timer (filtration times)



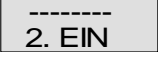



The integrated weekly timer for the filter pump is programmed with the key :

1. Press the key  ⇒  appears in the display.
2. The desired beginning of the first filtration time can then be set with the keys  and .
3. Press the key  again ⇒  appears in the display.
4. The desired end of the first filtration time can then be set with the keys  and .
5. Taste  erneut drücken ⇒ in der Anzeige erscheint .
6. Further filtration times can then be programmed as described in points 2-5. A total of 15 filtration times per week can be programmed.
7. To save the switch times, press the key  again. If, during setting, more than 10 seconds pass without a key being pressed, the last switch time displayed is saved automatically and the normal operating display appears again.

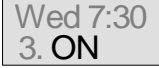
If filtration times have already been programmed, they can be deleted with the key :

1. Press the key  repeatedly until the filtration time that is to be deleted appears in the

display 

2. Set the filtration time on  with the keys  and  (between Sun. 23:59 and Mon. 0:00).
3. To delete the switch time, press the key  again.

Backwashing (manual)



A backwashing cycle can be started manually at any time – irrespective of how the timer has been programmed – with the key . The duration of the backwashing cycle is the same as that entered during programming of the timer.

This key can also be used to end a backwashing cycle already in progress.

Emptying the swimming pool



When the key  is pressed for longer than 5 seconds, the valve is turned into the position *Empty* and the filter pump switched on. Emptying can be stopped by pressing this key again.

Closing the valve



The key  is used to turn the valve into the position *Closed* for service purposes. In this valve position the filter pump is disabled. The valve is turned back into the position *Filter* by pressing this key again.

DIP switch on the upper circuit board

Intermittent backwashing and fortnightly backwashing can be activated with a DIP switch on the upper circuit board inside the EUROTRONIK. The housing has to be opened to access these operating elements.

The power supply to the device must be switched off first! Since the interior of the EUROTRONIK contains electronic components that react sensitively to the discharging of static electricity, the tools used must first be discharged by touching a grounded metal part. The electronic components should not be touched as far as possible.

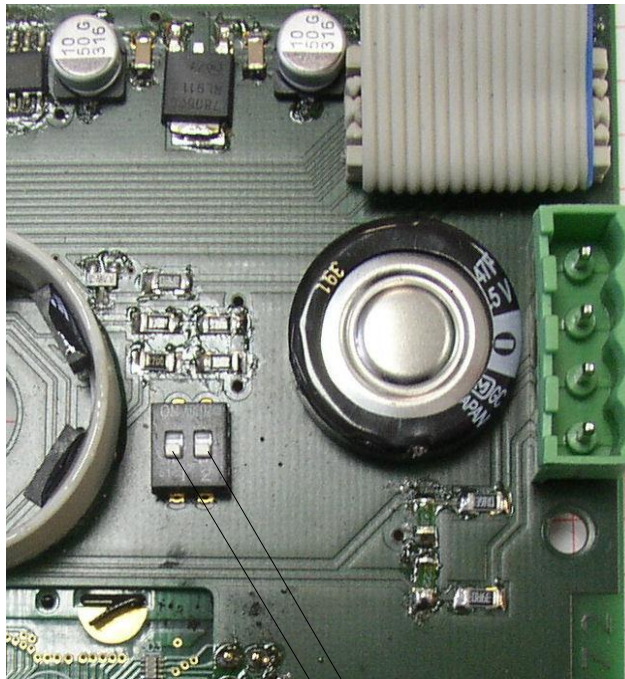

Intermittent backwashing

Fortnightly backwashing

Intermittent backwashing

The EUROTRONIK-10 offers two possibilities of controlling the filter pump during backwashing:

- a) Constant backwashing with continuous operation of the filter pump during the complete backwashing time.
- b) Intermittent backwashing with repeated switching on and off of the pump during the backwashing time for better loosening of the filter sand.

The right switch in the DIP switch is used to switch between intermittent backwashing and constant backwashing. The bottom switch position is for constant backwashing (factory setting) and the top switch position for intermittent backwashing.

Fortnightly backwashing

If, in the case of pools subject to little use, a backwashing cycle is only to be started every second week, the left switch in the DIP switch must be switched into the top switch position. If it is in the bottom switch position (factory setting), every switch command of the switch clock is carried out. In the top switch position only one backwashing cycle per week can be programmed with the switch clock. This backwash command is only carried out every second week.

Service terminal (only for service personnel)

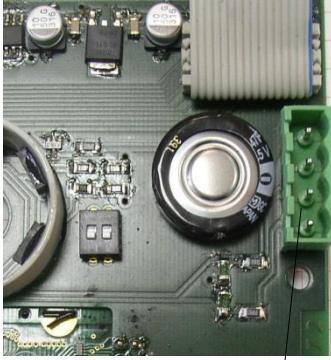

connector for service terminal

An osf service terminal (art. no. 3010000900) can be connected to this controller for optimum adjustment of the controller to the different types of swimming pool and to facilitate commissioning and fault diagnosis. The connector for this is mounted on the circuit board inside the device. **The power supply to the controller must be switched off before opening the housing and plugging in the service terminal! Plugging the service connector in or out when the device is on can destroy the device!** The operating time meter appears in the display of the service terminal after switching on the controller, e.g.:

Operating hours:	
total:	238
switched on	156
Filt.-pump	26

Further pages can be called up with the keys Δ and ∇ . If necessary, the values in the top line can be changed after pressing the key \downarrow .

Operating cycles of the backwash controller

The following counter statuses are shown:

<i>Backwash</i>	Number of completely carried-out backwash cycles.
<i>Empty</i>	Number of emptying cycles.
<i>Close</i>	Number of closing cycles.

Input signals

The current input signals of the EUROTRONIK are shown in this line:

<i>Pressure switch:</i>	Switch status of a pressure switch connected to terminals 10 and 11.
<i>B. fortnightly:</i>	Switch position of the left DIP switch (backwash fortnightly).
<i>B. interval:</i>	Switch position of the right DIP switch (intermittent backwashing).

Microswitch

The current status of the microswitch in the bottom part of the housing, which is used by the controller to detect whether the valve disk has been lowered, is shown on this page.

Light scanners

The measured values of the light scanners, which are used by the controller to detect the valve positions, are shown on this page. Two values are shown for each of the five light scanners. The value in brackets should be between 30 and 70. The other value should be more than 700 when the housing is open and should fall notably on approaching a reflecting object.

The following lines enable the service technician to check the output relays of the controller.

Heater

This line shows whether the relay K3 is on. This relay is used to activate the heater while the filter pump is on.



The following displays are possible:

<i>Heater: OFF</i>	The relay contact between terminals 3 and 5 (K3) is open, the heater is disabled.
<i>Heater: On</i>	The relay contact between terminals 3 and 5 (K3) is closed, operation of the heater is enabled.

When the heater is shown in the **top** line of the service terminal, it can be switched on or off:

1. The following display appears after pressing the key :

Heater: OFF Manual control of contact betw. terminals 3+5.

2. The heater can be enabled with the key  (K3 closed) and disabled again with the key  (K3 open).
3. The normal diagnostics display reappears when the key  is pressed again.

Filter pump

This line shows whether the relay K2 is on. This relay is used to switch the filter pump on or off.



The following displays are possible:

Filtration: OFF The filter pump is switched off (K2 open)
Filtration: ON The filter pump is switched on (K2 closed)

When the filter pump is shown in the **top** line of the service terminal, it can be switched on or off:

1. The following display appears after pressing the key :

Filtration: OFF Manual control of contact betw. terminals 2+4.

2. The filter pump can be switched on with the key  (K2 closed) and switched off again with the key  (K2 open).
3. The normal diagnostics display reappears when the key  is pressed again.

Auxiliary pump

This line shows whether the EUOTRONIK switches on an auxiliary backwash pump with the help of the contact K4.



The following displays are possible:

Backw.pump: OFF The pump is off (K4 open).
Backw.pump: ON The pump is on (K4 closed).

When the auxiliary backwash pump is shown in the **top** line of the service terminal, it can be switched on or off:

1. The following display appears after pressing the key :

Backw.pump: OFF Manual control of contact betw. terminals 6+7.

2. The backwash pump can be switched on with the key  (K4 closed) and switched off again with the key  (K4 open).
3. The normal diagnostics display reappears when the key  is pressed again.

Motor-operated valve

This line shows whether a motor-operated valve is opened or closed by the relay contact K1.



The following displays are possible:

Motor valve:SHUT The motor-operated valve is closed, terminal U3 is live with mains power.
Motor valve:OPEN The motor-operated valve is open, terminal U2 is live with mains power.

When the motor-operated valve is shown in the **top** line of the service terminal, it can be opened or closed:

1. The following display appears after pressing the key :

Motor valve:SHUT Manual control of motorvalve on terminals U2+U3

2. The motor-operated valve can be opened with the key  and closed again with the key .
3. The normal diagnostics display reappears when the key  is pressed again.

Servomotor

This line shows whether the servomotor in the EUOTRONIK to turn the 6-way valve is on or off.

The following displays are possible:

Act.motor: OFF The servomotor is off.





Act.motor: UP The servomotor lifts the valve disk or turns it into the next position.

Act.motor: DOWN The servomotor lowers the valve disk.

When the servomotor is shown in the **top** line of the service terminal, it can be switched on or off:

1. The following display appears after pressing the key :

Act.motor: OFF Manual control of drive (6-way-valve)

2. The valve disk can be lifted and turned with the key . Renewed pressing of the key  switches the servomotor off again.
3. The valve disk can be lowered into one of the valve positions with the key . The motor is switched off when the bottom final position is reached or the key is pressed again.
4. The normal diagnostics display reappears when the key  is pressed again.

Note!

The drain of the swimming pool must be installed in such a way that the pipe is higher than the water level at least at one point. A suitable ventilation valve must be installed at the highest point. The function of this ventilation valve is to ventilate the drain pipe whenever the filter pump is not in operation. This then prevents unnecessary water loss in the event of a leaking multiple-way valve.

These installation and operating instructions must be observed.

We wish you lots of fun and relaxation in your swimming pool.

Further information can be found on the Internet at the following address:

<https://osf.de/download/documents/documents.php?device=Eurotronik-20>

 **Hansjürgen Meier**
 Elektrotechnik und Elektronik GmbH & Co KG
 Eichendorffstraße 6
 D-32339 Espelkamp
 E-Mail: info@osf.de
 Internet: www.osf.de



